

13 STUDIO **RAZAVI** + PARTNERS

STUDIO **RAZAVI** + PARTNERS



13

STUDIO **RAZAVI** + PARTNERS

TABLE OF CONTENTS

THE FIRM	6	
RESIDENTIAL SINGLE-FAMILY	10	Mountain House II
	12	Mountain House
	14	House for a Photographer
	16	Forest House
	18	Mountain House III
	20	Mountain House IV
RESIDENTIAL MULTI-FAMILY	24	93 Petit
	26	47 Malakoff
	28	Maison de l'Italie
	30	Central Park Condominium
WORKPLACE	34	Motion Equity Partners
	36	August Debouzy
	38	Wakam Headquarters
	40	GRDF Headquarters
	42	Pradier Addition
HOSPITALITY	46	Boqueria West Loop
	48	Boqueria 40th Street
EXHIBITION DESIGN	52	Sotheby's 2022
	54	Sotheby's 2023
INTERIORS	58	Soho Triplex
	60	Apartment XVIII
	62	London Terraced House
	64	Apartment XVII
	66	Apartment XVI
FURNITURE	70	Alborz alpha
	72	Clessidra
	74	Shoji



STUDIO RAZAVI + PARTNERS

THE FIRM

STUDIO **RAZAVI** + PARTNERS is an international architecture and interior design practice spanning across Paris, London and New York.

We create sophisticated living, workplace & hospitality spaces relying on contemporary culture and craftsmanship as founding principles.

As a full service firm, we design buildings and interiors across a variety of typologies: single-family homes, condominiums, workplaces, art galleries, restaurants... Our commitment is to translate our clients' needs into memorable spatial experiences.

We service our clients - institutions, companies, private individuals - by setting up project specific teams to best respond to work phases and guide our clients through the full process of design and construction.

Licensed to practice in France, the United Kingdom and the United States, we have designed projects in Europe and the Americas.

RESIDENTIAL SINGLE-FAMILY

10	Mountain House II
12	Mountain House
14	House for a Photographer
16	Forest House
18	Mountain House III
20	Mountain House IV

Status Built
Client Private
Program Single family home

Area 200 m² (2.150 SF)
Date 2022
Photography Simone Bossi

Awards DNA Paris Design Awards 2023

MOUNTAIN HOUSE II

This house, located on the lower Alpine mountain regions, serves as a testimony of our evolving climate. A flat roof not only authorized by the local building code but highly welcomed as long as it can host vegetation and contribute to the building insulation capacity. With very high insulation values, limited openings facing South, this design mediates our ever changing technological challenges.



STUDIO RAZAVI + PARTNERS

10

RESIDENTIAL SINGLE-FAMILY

11



Status Built
Client Private
Program Single family home

Area 200 m² (2.153 SF)
Date 2016
MEP engineer Emenda

Photography Simone Bossi & Olivier Martin Gambier
Awards Archilovers Best Project 2017, Archi Design Club Awards 2018,
Iconic Awards 2018, German Design Awards 2019

MOUNTAIN HOUSE

In this highly preserved Alpine valley, stringent architectural guidelines allow for little architectural freedom. Strict guidelines are enforced to protect the local heritage but de facto create endless pastiche mountain homes. To circumvent these limitations we first became familiar with the existing history and culture so as to understand what functionally drove the designs. We then integrated this into our design, avoiding all artificial or obsolete elements while making sure that the building was entirely code compliant from a heritage standpoint. The base is all cast in place and exposed concrete and the floors above all wood, structure and cladding. Window openings gradually open up as the space allows for it. Celebrating nature was of course the pinnacle. This comes as the final experience, up on the last floor, fully framing the view by extending the building envelope to the outside. So as to protect the experience, material selection is kept at minimal variety.



STUDIO RAZAVI + PARTNERS

RESIDENTIAL SINGLE-FAMILY



Status Built
Client Private
Program Single family home

Area 105 m² (1.130 SF)
Date 2013

Photography Simone Bossi
Awards Archinovo AWARDS 2017

HOUSE FOR A PHOTOGRAPHER

The defining concept for this house, commissioned by a photographer as both his summer house and studio, was based on developed facade studies which define a simple and smooth building skin varied in height and punctured by openings. Two volumes define the main living & work spaces, both converge to the North corner freeing up as much space as possible on this small lot. The main space is compressed at the entry and releases up towards the landscape, the fan shaped plan gradually provides more floor area, volume and light. The second volume is exclusively dedicated to the photographer's studio. All rooms and bathrooms are reduced to a bare minimum and provide maximum surface area to living and work spaces. The varying angles at building edges offer a series of changing volumetric & perspective experiences (south facade reads as a single vertical plane). Similarly, an open angle on the main corridor defeats natural perspective to create an illusion of parallel walls.



STUDIO RAZAVI + PARTNERS

RESIDENTIAL SINGLE-FAMILY



Status Under Construction
Client Private
Program Single family home

Area 305 m² (3.288 SF)
Date Completion scheduled
for 2024

FOREST HOUSE

This house is located in a dense wooded area and our wish was to profit from this remarkable natural context to create a great variety of experiences from the inside out. The plan is based on two intersecting squares and diamond shaped in elevation as to gradually de-materialize and blend with the trees, some over 200 years of age. The dark wood siding and large window openings contribute to create a sense of refuge, of nestled habitation out in the open.



Status Competition
Client Private
Program Single family home

Area 400 m² (4,300 SF)
Date 2019

MOUNTAIN HOUSE III

The driving force behind this design is the relation between nature and humans. Throughout history the defining criteria for dwelling has been the degree to which one felt shielded from outside forces and as technology (and our perception of nature) evolved, the degree to which we could re-open our experience of space to the outside. Each floor in this chalet is slightly cantilevered out with glazing mounted inbound by a foot so as to create a photographic framing device to the landscape. On the mountain facing side, the building is connected through a concrete footbridge that further outlines the different stages of dwelling.



Status Built
Client Private
Program Renovation

Area 213 m² (2,293 SF)
Date 2024
Photography Simone Bossi

MOUNTAIN HOUSE IV

We were tasked with the full refurbishment of this all-concrete 1980s chalet at the edge of a high-altitude French ski resort. Facade changes required landmarks approval and posed the challenge of modifying load-bearing concrete walls.

In order to preserve the chalet's facade patina, interior layout changes were carefully considered for their exterior impact. This allowed a seamless transition from old to new, aspiring to form a coherent ensemble over time.

Interiors focus on simple craftsmanship and emulating the high-altitude chalet experience, using a limited selection of materials. We created a hierarchy of openings to ensure each room offers unique experiences, making the house feel unified and harmonious.



STUDIO RAZAVI + PARTNERS

INTERIORS



RESIDENTIAL MULTI-FAMILY

24	93 Petit
26	47 Malakoff
28	Maison de l'Italie
30	Central Park Condominium

Status Built
Client Emerige
Program 168 apartments & retail

Area 10.585 m² (113.936 SF)
Date 2023
Photography Schnepf Renou

Structural engineer Bollinger +
Grohmann
MEP engineer INEX
Quantity surveyor AE75
Landscape design OLM
Acoustic design Acoustique & Conseil
Environmental engineer Oasiis
Project manager Auris

93 PETIT

This building sits on a very large rectangular site with the shortest side facing the street. This specific criteria, combined with the necessity to maximize square footage helped us create a typology that responded not only to zoning restrictions but also created a series of differentiated buildings envelopes which help break down the overall scale. A total of four building blocks make up the project. The longest runs North-South to allow maximum sunlight exposure to the West, three remaining blocks run parallel to the street, opening both to North and South sides. The farther the building in the site, the shorter it is. Terraces set the buildings back to the East side, offering a more gentle scale to neighboring buildings. Brick was the material of choice in order to introduce yet another dimension and scale to our design and help, via the tactile properties of the material, create a more intimate scale and vibrant facades.



STUDIO RAZAVI + PARTNERS

RESIDENTIAL MULTI-FAMILY



Status Awaiting planning approval
Client Private

Program Student residence
Area 1.656 m² (17.822 SF)
Date 2025

47 MALAKOFF

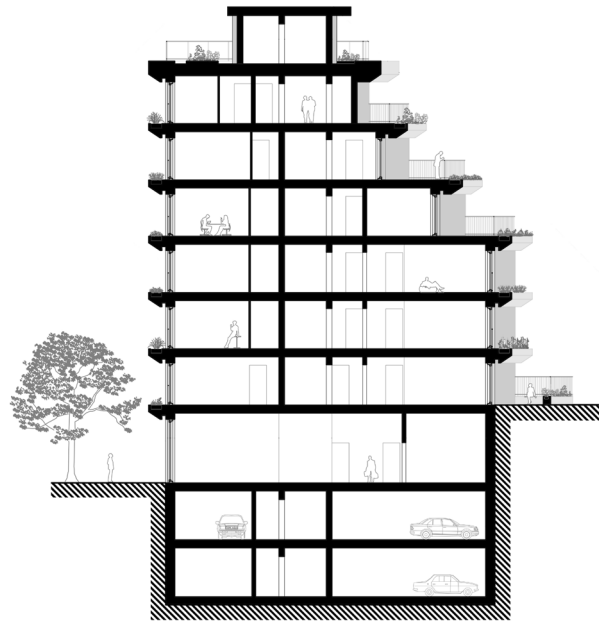

With each new development, towns and cities shape their identity and future appeal to new residents. In an era of sensible urban renewal, this project exemplifies how fresh designs can address contemporary challenges while preserving community identity.

Our building's plot has two radically different scales on either side, which we wanted to highlight. The main road facade is a planar surface with terrace cutouts, while the opposite facade steps back to echo the scale of nearby single-family homes. The layout is based on a central vertical circulation core with apartments on either side and prefabricated concrete facade panels integrating planters. Using concrete prefabrication enhances structural integrity and detailing precision.

STUDIO RAZAVI + PARTNERS

RESIDENTIAL MULTI-FAMILY



Status Permits approved
Client Maison de l'Italie
Program Student residence

Area 827 m² (8.902 SF)
Date 2026

Awards Word Architecture Festival 2021

MAISON DE L'ITALIE

The Italian Foundation at the Cite Universitaire campus commissioned us to design their new building aimed at increasing their room capacity as well as creating a new Italian cafeteria on the ground floor. The only site available for this new building was a collection of constraints: proximity of existing building, proximity of remarkable trees, limited constructable footprint. To which we responded with a shape that seemed to be the only one to accommodate them all. A cylinder shaped building presents itself with its own sets of constraints but in this instance, the repetitive nature of identical bedrooms actually lent itself quite appropriately to the geometry. The concrete structure allows a clear expression of all floors plates and a set of columns lift the building off the ground so as to not interrupt the view corridor down to Le Corbusier's Swiss pavilion.



STUDIO RAZAVI + PARTNERS

RESIDENTIAL MULTI-FAMILY



Status Concept Design
Client Private
Program 10 apartments

Area 930 m² (10,000 SF)
renovation + 1,400 m² (15,000 SF)
extension

Date 2014

CENTRAL PARK CONDOMINIUM



The opportunity to imagine a new building facing Central Park, a few blocks from Frank Lloyd Wright's Guggenheim museum is as rare as it gets. What we offered was to celebrate both a rich urban fabric and the importance of renewal. Fernand Leger and Le Corbusier emphasized the importance of Form Contrasts as a means to bring about harmonies relevant to the post-classicist, machine age they lived in. Building over an existing Georgian brick townhouse, surrounded by imposing all-brick 5th avenue, Florentine inspired palazzo architecture, poses a similar design strategy challenge. Opposing large curved glass panes to flat brick surfaces, floor to ceiling openings to 19th century double hung window openings speaks not only about technical evolution, changing life styles but foremost about urban vitality.

STUDIO RAZAVI + PARTNERS

RESIDENTIAL MULTI-FAMILY



WORKPLACE

34	Motion Equity Partners
36	August Debouzy
38	Wakam Headquarters
40	GRDF Headquarters
42	Pradier Addition

Status Built
Client Motion EP
Program Headquarters

Area 870 m² (9.364 SF)
Date 2024
Photography Simone Bossi

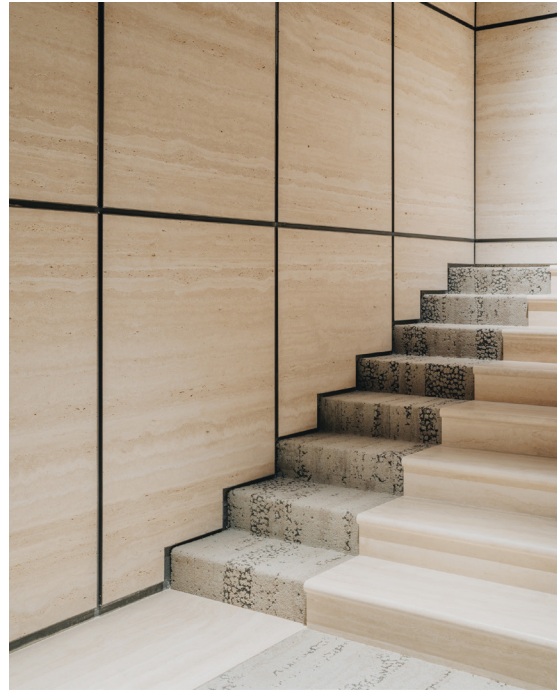

The all-concrete 1960s building provided our primary source of inspiration when designing this headquarter for a Paris-based private equity firm. Walnut and travertine paneling set the tone for an intimate but sharp work environment, enhanced by a selection of furniture systems. A large central hallway functions as the office's "main street", connecting offices, meeting rooms, cafeteria etc. to create a constant flow and life in the workplace. All offices open up to the central hallway on one side and on to courtyards or gardens on the other, providing everyone with natural lighting.



MOTION EQUITY PARTNERS

WORKPLACE



Status Built
Client August Debouzy
Program Headquarters

Area 6.542 m² (70.417 SF)
Date 2020
Photography Simone Bossi

Awards Architizer A+ Award 2022, Loop Design Award 2022, Archello Award 2023

AUGUST DEBOUZY



The past decade saw the advent of new spatial organizations in office design in response to the growing transformation of the workplace as new tools & methods were introduced, largely driven by technology firms. Concepts of flexibility, working remotely, co-working, blending residential & corporate design solutions took root. Slowly however, our own perception of this trend was challenged as notions of permanence and familiarity seemed to have been sacrificed to benefit a less formal approach. Our objective for this project is to create spaces that are here to age and not look obsolete as trends evolve. One way to accomplish this is to aim for a nuanced classicism and draw upon the great examples of corporate design over the past century. Connecting with past great designs not just as a show of admiration but also humility and strength, qualities that hopefully permeate and reflect a team's remarkable values.



Status Built
Client La parisienne assurances
Program Headquarters

Area 700 m² (7.535 SF)
Date 2015
Consultant The boson project

Photography Olivier Martin Gambier
Awards German Design Awards 2019

WAKAM HEADQUARTERS

This full floor work space was designed for the oldest insurance company in France. A very specific brief had been put together by the client which required to design a “peaceful, see-through & fresh” space that would not only respond to contemporary work practices but also allow new, and at times unexpected, team interactions. We opted for materials that are not commonly thought of for work spaces and tried to use them sensibly to establish a core identity, combining wood, carpet & glass partitions. Pine was the wood of choice because of its very imperfections. Centrally located on the floor plate are “program islands” which allow existing structure to be concealed, create storage & a variety of other programs such as reception desk, stand-up meeting rooms and storage.

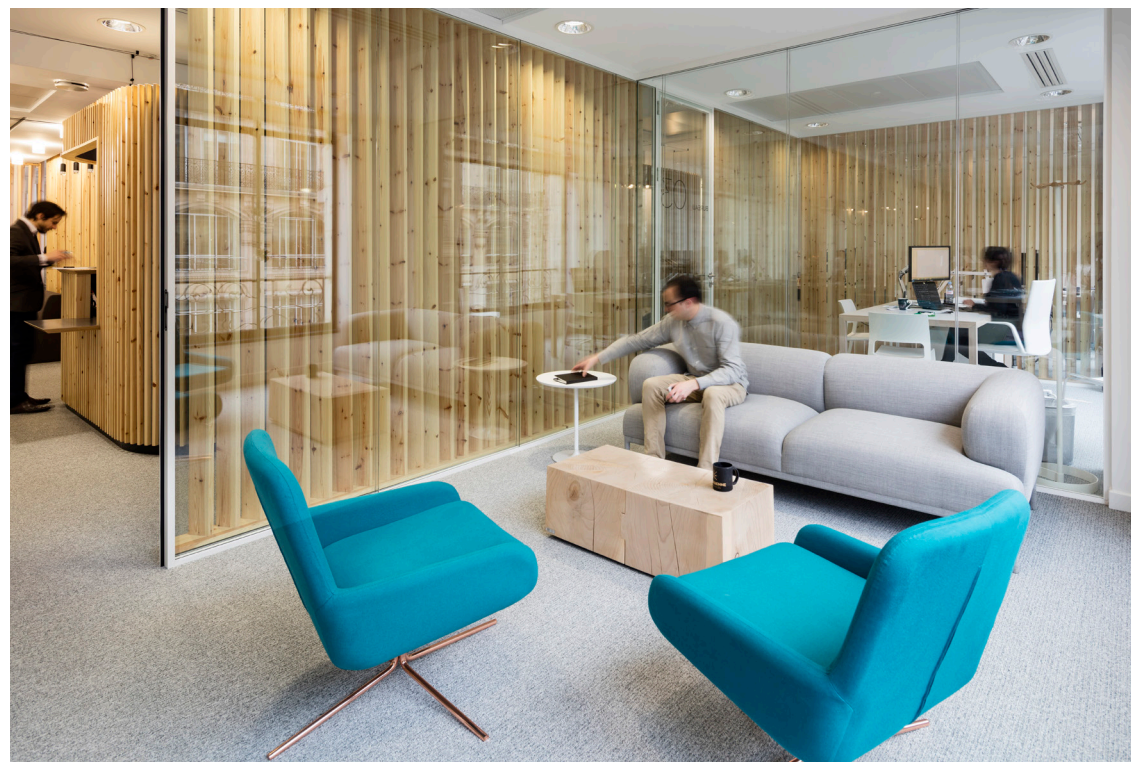

STUDIO RAZAVI + PARTNERS

WORKPLACE



Status Concept Design
Client Société Foncière
Lyonnaise

Program Offices & retail
Area 3.200 m² (34.444 SF)
Date 2027

GRDF HEADQUARTERS

For the former headquarters of French natural gas distributor GRDF, our approach was to consider each space as part of a story and a fragment of urban life, with variations in scale and new discoveries to be made. Each space creates a distinct atmosphere, showcases a different craft and offers its own unique appeal. Our design choices take into account the characteristics of the existing building, ensuring an appropriate response.

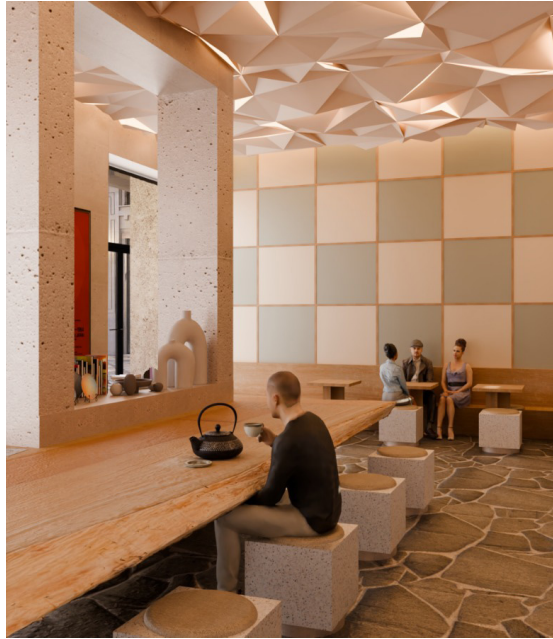

Status Competition
Client Private
Program Mixed use

Area 700 m² (7.535 SF)
renovation + 800 m² (8.611 SF)
addition

Date 2019

PRADIER ADDITION



Following its completion in the early 1900s, this private mansion was gradually transformed, first to be converted into an office building and then, starting in the 1950s, new floors were added with the last floor built in the 1980s. Because the top original floor had been demolished and the floors added had attempted to blend in, the end result had become an eyesore. However, because no one can afford to lose real estate, our proposed design offered to demolish all non-original floors and build an entirely different structure on top, preserving (and increasing) square footage but more importantly, making sure the new and old would celebrate each other. Particular emphasis was put on the threshold between the two buildings: the reduced footprint of the lower arches are here to signal a light interface, respectful & delicate. Sharply different finishes further provide contrast between the buildings.

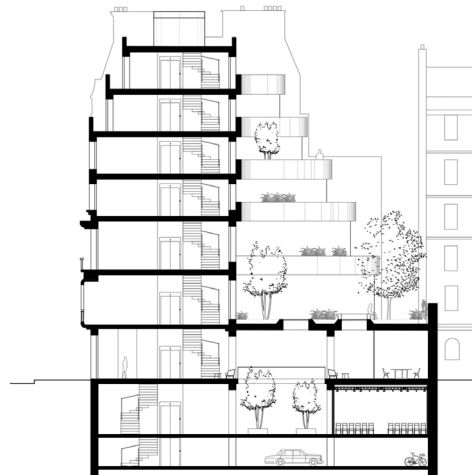

STUDIO RAZAVI + PARTNERS

WORKPLACE



HOSPITALITY

46 Boqueria West Loop
48 Boqueria 40th Street

Status Built
Client Private
Program Restaurant

Area 404 m² (4.350 SF)
Date 2019
Lighting designer Kugler Ning

Once a design has contributed defining a brand, growth poses an interesting challenge for architects. How does one convey an established identity and familiarity of brand while refraining from copy pasting previous designs over to a new location? Boqueria in Chicago is located in the West Loop, in the former industrial & meatpacking neighborhood of Fulton-Randolf District which is being currently gentrified. Most buildings, new & old, have retained an industrial look: large open floor plates with columns. Because these spaces are predominantly horizontal in proportion, our approach was to layer the information so the design in its totality would provide a clear understanding of how it is organized. Prevailing materials are wood and black tiles, both not only reminiscent of the original Boqueria but also because of the feelings associated with them. One taking on a nice patina over time, the other providing a feeling of permanence & protection throughout the space. All light fixtures have been custom designed to create a variety of lighting atmospheres but also as a reminder of the eclecticism of Boqueria.

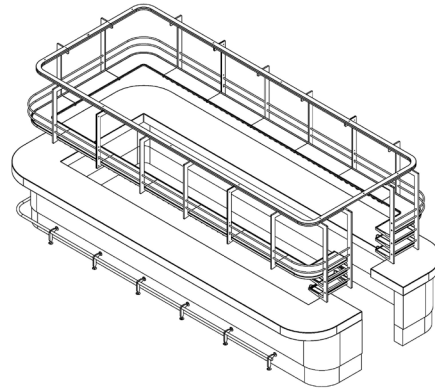

STUDIO RAZAVI + PARTNERS

HOSPITALITY

BOQUERIA WEST LOOP



Status Built
Client Boqueria
Program Restaurant

Area 440 m² (4,736 SF)
Date 2018
Lighting designer Kugler Ning
Photography Simone Bossi

Light fixtures design Tourmaline
MEP engineer Stantec
AOR Lenart Architecture
Awards James Beard Foundation 2019, Hospitality Design Awards 2019, Architizer A+Awards, Restaurant & Bar Design Awards

BOQUERIA 40TH STREET

A restaurant concept derived from the famous Barcelona market housed under a single great roof structure, inspired us to create an all-encompassing atmosphere, not dissimilar to the market. Using only wood, our design intent was to mitigate the changing ceiling heights (some in excess of 20') with one varying surface made up of wood slats. These would then curve down to extend along walls to create a warm texture, which would gradually disappear as it reaches down. A centrally located bar becomes the prominent spatial element and stands out as a vital organ along with the open kitchen, opposite the main seating area, therefore surrounding clients with the two main features of what a tapas restaurant is all about.



STUDIO RAZAVI + PARTNERS

HOSPITALITY



EXHIBITION DESIGN

52 Sotheby's 2022
54 Sotheby's 2023

Status Built
Client Sotheby's
Program Exhibition

Area 200 m² (2.150 SF)
Date 2023
Photography Ambroise Tezenas



For our second collaboration with Sotheby's we continued our spatial exploration of how a site specific exhibition design can impact the visitor's experience and create a new relationship with the art being shown. This time around, our design has a more minimal contact with floors, freeing up more circulation possibilities, perspectives. As we experienced it, it also created a more playful and dynamic behaviour with visitors as they sought to look around and make sure they had seen all the works.



STUDIO RAZAVI + PARTNERS

EXHIBITION DESIGN



Status Built
Client Sotheby's
Program Exhibition

Area 200 m² (2.150 SF)
Date 2022
Photography Ambroise Tezenas

SOTHEBY'S 2022



On the occasion of Sotheby's first Surrealism auction held in Paris, the wish was expressed to create a memorable experience for visitors, clients and online bidders. The Galerie Charpentier is a Parisian landmark with the main exhibition hall in a former (glass roof covered) courtyard, square in shape. Our objective was to create a space within this space with an expressed economy of means. Our design, an "open" cruciform plan which doubles the existing wall surfaces, offers multiple perspectives and a variety of circulation possibilities, while relying on its monolithic nature to both be stable and provide a sense of mass. The freestanding partitions are carved open in the center to allow Magritte's *La Joconde* to become a focal point of the exhibition from which one can walk around the galleries.



INTERIORS

58	Soho Triplex
60	Apartment XVIII
62	London Terraced House
64	Apartment XVII
66	Apartment XVI

Status Built
Client Private
Program Renovation

Area 415 m² (4,470 SF) interior
+ 130 m² (1,400 SF) terraces
Date 2022

Lighting Sichte Studio LLC
MEP engineer CES Engineering LLC
Structural engineer EIPEL Engineering DPC
Photography Simone Bossi

SOHO TRIPLEX

An existing duplex was combined with the top floor of this Soho building to create a single-family home with rooftop & terrace access. Two separate floor openings were devised, with a large bronze-finished helix acting as the house's central core and creating a feeling of generosity on an otherwise modest floor plate. A material palette comprising walnut, marble, glass, steel, bronze and finely woven fabrics, including custom designed furniture pieces and a selection of mid-century and contemporary designers, elevate the experience.



STUDIO RAZAVI + PARTNERS

INTERIORS



Status Built
Client Private
Program Renovation

Area 215 m² (2.315 SF)
Date 2021
Photography Vincent Leroux

APARTMENT XVIII



An L-shaped apartment facing the Luxembourg gardens, light coming in from 3 different orientations. A restrained selection of finishes and a formal strategy making abundant use of curved shapes to avoid hard shadows all contribute in creating a peaceful space, where sound, light & vision all become part of a coherent whole.

Status Built
Client Private
Program Renovation

Area 432 m² (4.650 SF)
Date 2020
Photography Vincent Leroux

Lighting Xavio design
MEP engineer P3r Engineers Ltd
Structural engineer Eckersley O'Callaghan

LONDON TERRACED HOUSE

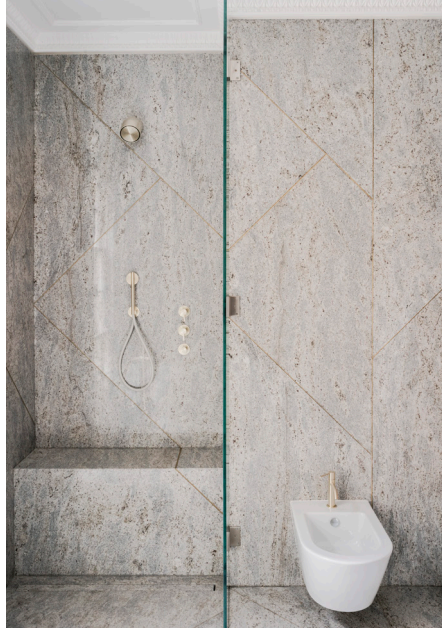

Located in central London, this XIXth century grade II listed terraced home has undergone extensive gut renovation to restore it to its former glory. A new steel and glass contemporary conservatory was added in lieu of the existing one to capture the most of natural lighting. A sensitive combination of mid century furniture was combined with the original features to create just the right balance.



STUDIO RAZAVI + PARTNERS

INTERIORS



Status Built
Client Private
Program Renovation

Area 80 m² (861 SF)
Date 2019
Photography Simone Bossi

APARTMENT XVII

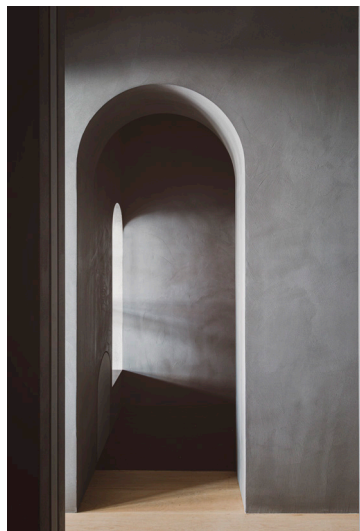

This is an apartment designed for a young scientist, living mostly alone. The XVIth century building is part of a uniquely preserved Renaissance neighborhood in the city of Lyon, France. Two massive stone fireplaces, oversized oak beams, 14 foot ceilings were some of the original features we intended to renovate & celebrate in the new space. A single bedroom and bathroom, in addition to living room, dining room and kitchen, made up the program. Relying primarily on the use of a single material with a limited color palette, we designed a series of events so as to create what we refer to as an "introspective space", a place to allow for reflexion, for creative seclusion. Wood floors, rough plasterwork on walls are the only other materials used, allowing for full potential of the space to be celebrated.

STUDIO RAZAVI + PARTNERS

INTERIORS



Status Built
Client Private
Program Renovation

Area 145 m² (1.560 SF)
Date 2018
Photography Simone Bossi

APARTMENT XVI



Across the street from the Luxembourg gardens, the building sits inside a 17th century hotel particulier courtyard. Man Ray, Hemingway and Jacques Prévert all lived across the street. The apartment belongs to a French American couple and this is their parisian home. Our brief was to transform the place into a warm & contemporary parisian apartment and allow as much flow between each room. The brief also required to provide mutiple opportunities to show an eclectic art collection, ranging from antiquities to contemporary works.

STUDIO RAZAVI + PARTNERS

INTERIORS



FURNITURE

70	Alborz alpha
72	Clessidra
74	Shoji

ALBORZ ALPHA

Manufacturer Lallier
Material Black lacquered MDF

Dimensions 60 x 76 x 72 cm / 23.6 x 30 x 28.3 in
Date 2020



STUDIO **RAZAVI** + PARTNERS

70

ALBORZ ALPHA

Manufacturer Lallier
Material Black lacquered MDF

Dimensions 65 x 52 cm / 25.6 x 20.5 in
Date 2020



FURNITURE

71

Manufacturer Blanc Carrare & Margraf
Material Rosa Peralba marble

Dimensions 105 x 70 x 35 cm / 41.3 x 27.5 x 13.8 in
Date 2018

Photography Simone Bossi

CLESSIDRA

A shape often explored in the past, the hourglass offers both tension and balance. Seen from above it also appears to be a weightless disc floating above ground and as one sits and lowers its sight-line, the base and connecting points are revealed. Taking on from this, two hourglasses of different diameters were merged to form a coffee table with the desired dimensions. Carved out of a single block, the table offers continuity of veins, rhythm and ever changing shapes as one turns around it.

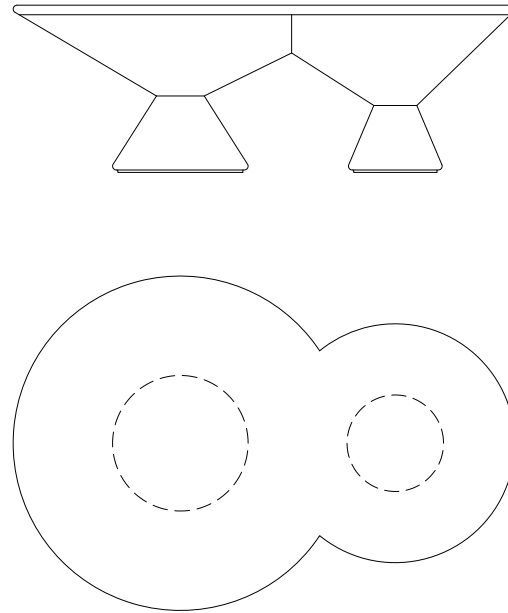

STUDIO **RAZAVI** + PARTNERS

FURNITURE



Manufacturer Gau lighting
Material Green marble, copper, rice paper

Dimensions 42 x 20 x 123 cm / 16.5 x 8 x 48.4 in
Date 2018

Photography Simone Bossi

SHOJI

A marble base for stability, a bent copper pipe for scale and rice paper lampshade make up this simple design. Inspired by the straightforward mid-century aesthetic and manufactured by GAU lighting, a century old family owned business, this lamp provides just the right presence, both in terms of design and lighting.



STUDIO RAZAVI + PARTNERS

FURNITURE





EXHIBITIONS, AWARDS & TALKS

Exhibitions

Institut Français (Milan), 2022
Le French Design 100 (Paris), 2022
The Alborz Collection (Paris), 2021
Galerie d'Architecture (Paris), 2018
XV Architecture Biennale (Venice), 2016
Architecture of Necessity Triennale (Virserums), 2016
Exo Architectures, Pavillon de l'Arsenal (Paris), 2008

Awards

Le French Design 100 Awards, (Winner), 2024
Archello Awards, (Winner), 2023
AIA International, (Commendation), 2023
DNA Paris Design Awards, (Winner), 2023
Loop Design Awards, (Honorable Mention & Winner), 2022
A+Awards, (Winner), 2022
Le French Design 100 Awards, (Winner), 2022
Best of Interior 21, (Special Mention), 2021
Restaurant & Bar Design Awards, (Shortlisted), 2021
A+Awards, (Special Mention), 2021
Archilovers, (Best Project), 2020
Loop Design Awards, (Honorable Mention & Winner), 2020
A+Awards, (Special Mention), 2019
German Design Awards, (Special Mention), 2019
Archinovo, (Shortlisted), 2019
Hospitality Design, (Finalist), 2019
Restaurant & Bar Design Awards, (Shortlisted), 2019
James Beard Award, (Finalist), 2019
VIA Le French Design, (Recipient of FD100 Award), 2019
German Design Awards, (Special Mention), 2018
German Design Awards, (Special Mention), 2018
Iconic Awards, (Winner), 2018
Archi Design Club Awards, (Shortlisted), 2018
2A Awards, (Second place), 2017
Iconic Awards, (Winner), 2017
WIN Awards, (Shortlisted), 2017
A+Awards, (Shortlisted), 2017
The Plan Award, (Shortlisted), 2017
Académie d'Architecture, (Winner Lounsbery medal), 1997
Conservatoire National des Arts et Métiers, (Winner Besnard de Quelen price), 1996

Talks

Guest Speaker at Architect@Work (Paris), September 2022
Guest Speaker at the Forum Perspective Europe by The Plan Magazine (Venice), May 2017
Guest Speaker at the Idea-Tops Design Awards (Shenzhen), December 2016
Guest Speaker at the Forum Perspective USA by The Plan Magazine (New York), July 2016

PUBLICATIONS BOOKS

Slow Living Interiors

Loft Publications, 2023

All About Chalets

Sibylle Kramer, Braun, 2022

House of Joy, Playful Homes and Cheerful Living

Gestalten, 2022

Winter Homes, Cozy Living in Style

Jeanette Wall, 2021

Living in the Mountains

Phaidon, 2021

Where We Work

Frame, 2021

Out of the Woods

Robert Klanten, Gestalten, 2020

Snowbound

William Morgan, Princeton Architectural Press, 2020

Where Architects Sleep

Sarah Miller, Phaidon, 2020

White Houses

Philip Jodidio, Thames & Hudson, 2019

Yunomi, Vol° 1

Marie Boyard, 2018

HomeWork

Anna Yudina, Thames & Hudson, 2018

Small Innovative Houses

Philip Jodidio, Rizzoli, 2018

Sketch Book

Jung Heungchae, A&C Publishing Co., Ltd, 2018

Inside Modern Workspaces

Natalia Heib, Deutscher Architektur Verlag, 2017

PUBLICATIONS MAGAZINES

La Vanguardia Magazine, 2024

WhitePaperby, N°19, 2024

Imagicasa, Summer edition, 2023

Sudissimo, N°20, 2023

NDA, N°50, 2022

A Vivre, Hors Série, N°55, 2022

Interior+Design, N°6-7, 2022

IDEAT, Hors-Série, N°22, 2022

Abitare, N°611, 2022

Bau Meister, N°118, 2021

AD 100 Best Designers, Hors Série, N°24, 2021

Elle Décoration France, 2021

Elle Décoration China, 2021

AD Middle East (cover), 2020

Elle Décoration Netherlands, 2020

Das Ideale Heim (cover), N°12/1, 2020

Elle Décoration UK, 2020

Interior Magasinet (cover), 2020

Déco Idées, N°256, 2020

Traumhaus (cover), N°6, 2020

Nya Rum, N°01, 2020

Marie Claire Maison, N°514, 2019

Bob, N°183, 2019

AD 100 Best Designers, Hors Série, N°20, 2019

d'A, N°269, 2019

Art & Décoration, N° 538, 2019

Architecture & Stations, N° 11, 2018

Bati architecture, 2018

USM Magazine, N° 2, 2018

Casa Claudia, N° 42, 2018

AD 100 Best Designers 2018, N° 18, 2018

Maisons & bois, N° 140, 2017

AB architecture bois, N° 83, 2017

À Vivre, Hors Série, N° 34, 2017

AD China (cover), N° 2-917, 2017

AD 100 Best Designers 2017, N° 16, 2017

AD Italia, N° 427, 2017

AD Russia, N° 168, 2017

AD Spain, N° 125, 2017

Landscape Design, N° 82, 2017

Maru (cover), N° 185, 2017

Bob, N° 150, 2017

Trends, N° 3, 2017

Maru, N° 182, 2017

Top Decoration World, N° 5, 2017

Vogue Living (cover), Nov / Dec, 2016

Trends, N° 10, 2016

Maru, N° 170, 2016

AD Germany (cover), N° 174, 2016

100 Working Spaces, Ausgabe 16/17, 2016

Home Journal HK, Vol° 355 N° 414, 2015

House and Garden, Vol° 70 N° 12, 2015

Mindfood Décor, Winter edition, 2015

Côté Paris, N° 40, 2015

Better Homes, N° 107, 2015

AD Spain, N° 108, 2015

AD Spain, N° 105, 2015

AD Russia (cover), N° 141, 2015

AD Germany special, N° 159, 2015

AD France, N° 129, 2015

AD 100 Best Designers 2015, N° 12, 2015

AD Spain, N° 97, 2014

AD Russia, N° 133, 2014

Architektur & wohnen, N° 3, 2014

Côté Paris, N° 29, 2013

The Plan, N° 51, 2011

d'A, N° 205, 2011

d'A, N° 197, 2011

d'A, N° 193, 2010

The plan, N° 44, 2010

Architecture créé, N° 339, 2009

d'A, N° 168, 2007

Ideat, Hors Série N° 7, 2016

Ideat, N° 121, 2016

AD Russia, N° 157, 2016

info@studiorazavi.com

www.studiorazavi.com